



Standard control valve RC200

USA Type 807,752



Features

- Control valve in sizes 1", 3/4", 1/2" and 1/4"
- Globe cast body
- Maximum allowable pressure 340 bar
- Suitable for control of medium and low flow
- Many variations not listed here

Applications

Suitable for control of liquids, gases or steam, in industrial applications, research, and process pilot plants. Its compact size makes it an ideal choice for additive injection, sampling, low flow hydraulic systems or wherever precise control is an important factor or physical constraints limit valve weight or size.

Connections

Standard is NPT-internal thread.
For other types, see **Data Sheet CON.**

Guiding

Standard as pictured on page 2 or optional medium and heavy duty guiding, see **Data Sheet GDG.**

Bonnet

Standard as pictured on page 2. Other types available are for example:
Cooling fin bonnet, see **Data Sheet CFG.**
Bellows sealed bonnet, see **Data Sheet BLW.**

Packing

Standard are PTFE chevron rings.
For other type, see **Data Sheet PCK.**

Pneumatic actuator

Die cast Aluminium with Epoxy paint, optional 316L S/S (Stainless Steel) but only for 1/2" valves.
Standard actuator "Spring to close" **Data Sheet AC-OS**
Standard actuator "Spring to open" **Data Sheet AC-CS**
With integrated pneumatic positioner:
Standard actuator "Spring to close" **Data Sheet AC-OP**
Standard actuator "Spring to open" **Data Sheet AC-CP**
Various accessories on request.

Electric actuator

Various special types available: explosion proof, safety position "Spring to open" or "Spring to close".
Electric **Data Sheet AC-HH500 AC-M60WE**
Electronic **Data Sheet AC-EVA1 AC-MC60**

Dimensions

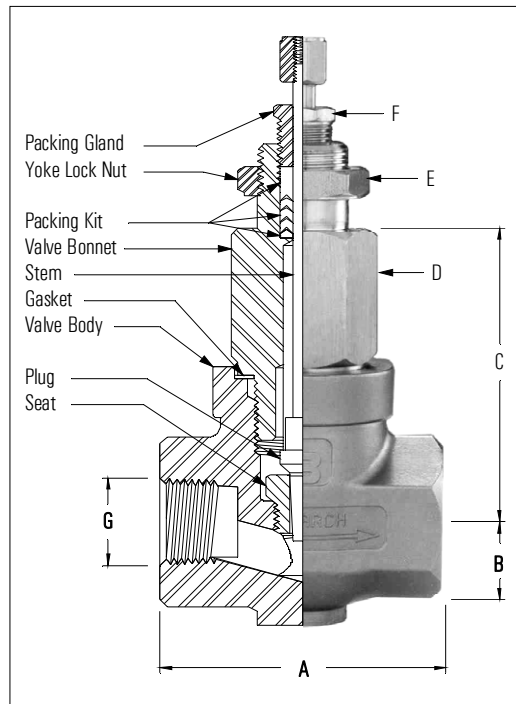

G	A	B	C	D	E	F	Lift
1" NPT*	102	38	100	1-3/4"	1-1/8"	1/2"	14,3
3/4" NPT*	86	30	99	1-1/2"	1-1/8"	1/2"	14,3
1/2" NPT*	70	25	72	1-1/4"	1-1/8"	1/2"	14,3
1/4" NPT*	54	17	48	7/8"	7/8"	7/16"	11.1

Innervalue materials

Size	Plug	Seat
V - 0	316 SS	316 SS
V - P18	Stellite ⁽¹⁾	416 SS
V - P18	Stellite ⁽¹⁾	316 SS stelled ⁽¹⁾
V - P5	Monel	Monel
V - P9	Alloy-20	Alloy-20
V - P9	Alloy-B	Alloy-B
V - P13	Alloy-C276	Alloy-C276
A - 0	Tantalum	Tantalum
V - P13	Additional Titanium nitride coating	

Other materials available on request. Up to now over 140 materials and materials combinations have been used. (316 SS ~ 1.4571).

⁽¹⁾ Stellite[®] is a registered trademark of Deloro Stellite Holdings Corporation.

Pressure-temperature rating body

	°C	1.4581	Alloy-B	Alloy-C	Monel	Alloy20	length bonnet
1" CONTROL VALVE	20	100	see type RC250	see type RC250	see type RC250	see type RC250	STD
	100	93					
	200	82					
	300	55					CF
	400	17					
	500	-					
600	-	EF					
3/4" CONTROL VALVE	20	100	see type RC250	see type RC250	see type RC250	see type RC250	STD
	100	99					
	200	82					
	300	73					CF
	400	48					
	500	-					
600	-	EF					
1/2" CONTROL VALVE	20	340	320	320	276	320	STD
	100	320	320	320	258	320	
	200	269	320	320	236	320	
	300	242	320	320	234	302	CF
	400	226	310	310	184	382	
	500	190	-	285	115	175	
600	-	-	230	-	-	EF	
1/4" CONTROL VALVE	20	340	320	320	276	320	STD
	100	320	320	320	275	320	
	200	292	320	320	260	320	
	300	267	320	320	258	295	CF
	400	249	320	320	249	262	
	500	159	-	299	128	174	
600	-	-	237	-	-	EF	
max. pressure in bar							

STD = standard bonnet. Details about bonnet length CF and EF, see **Data Sheet CFG**

The above pressure ratings alone are not sufficient to determine if a valve is suitable for an application.

You can find help for selection of innervalue, material combinations, guiding, bonnet and actuator in the "instruction for valve selection" and the **Data Sheets TRM, GDG, CFL resp. AC**.

Valve materials

Body	Bonnet
1.4581 steel casting	1.4571 barstock
1.4571 forged	1.4571 barstock
316 SS steel casting	316 SS barstock
Monel casting	Monel barstock
Alloy-20 steel casting	Alloy20 barstock
Alloy-B casting	Alloy-B barstock
Alloy-C casting	Alloy-C barstock

For other materials see type RC250.



Innervalue chart

NW	Size	Cvs	NW	Size	Cvs
	V	6,0		0	0,003
	U	5,0		P1	2,0 E-03
	T	4,5		P2	1,3 E-03
	S	4,0		P3	1,0 E-03
	R	3,5		P4	6,0 E-04
	A	2,5		P5	4,0 E-04
	B	2,0		P6	2,7 E-04
	C	1,25		P7	1,8 E-04
	D	0,80		P8	1,2 E-04
	E	0,50		P9	8,0 E-05
	F	0,32		P10	5,0 E-05
	G	0,20		P11	3,6 E-05
	H	0,13		P12	2,4 E-05
	I	0,08		P13	1,6 E-05
	J	0,05		P14	1,0 E-05
	K	0,03		P15	6,0 E-06
	L	0,02		P16	4,0 E-06
	M	0,01		P17	2,7 E-06
	N	0,006		P18	1,8 E-06

Size	1"	3/4"	1/2"	1/4"

For detailed information, see [Data Sheet TRM](#)

Innervalue characteristic

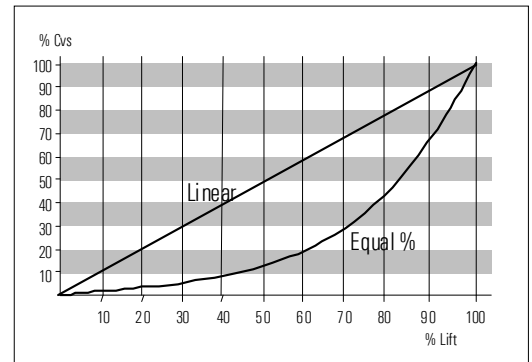

Seat leakage

0.01% of Cvs for "0" and larger ANSI Class IV

0.1% of Cvs for "P1" and smaller ANSI Class III

Optional: Metallic or soft seated (PTFE or Kel-F).